

FACE MILL ARBOR (Type A)

ST^(No)-FMA^(D2)

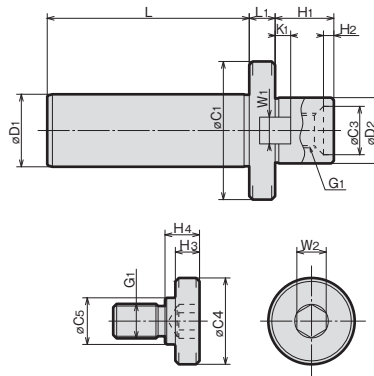

MODEL	CODE	øD1	øD2(h6)	L	L1	øC1	øC3	H1	H2	KEY		G1	CLAMP BOLT					CLAMP BOLT	N/W (kg)
										W1	K1		øC4	øC5	H3	H4	W2		
ST32	-FMA25.4	30462	25.4	112	15	50	◇	22	◇	9.5	5	M12	33	23	10	12	10	MBA-M12	1.1
	-FMA31.75	30464	31.75		15	60	24	30	6	12.7	7	M16	40	23	10	16	14	-M16	1.3
	-FMA38.1	30466	38.1		18	80	28	34	6	15.9	9	M20	50	27	14	20	17	-M20	1.9
ST42	-FMA25.4	30468	25.4	117	15	50	◇	22	◇	9.5	5	M12	33	23	10	12	10	MBA-M12	1.7
	-FMA31.75	30470	31.75		15	60	24	30	6	12.7	7	M16	40	23	10	16	14	-M16	1.9
	-FMA38.1	30472	38.1		18	80	28	34	6	15.9	9	M20	50	27	14	20	17	-M20	2.5
	-FMA50.8	30474	50.8		20	100	38	36	10	19.0	10	M24	65	37	14	24	17	-M24	3.4

ORDERING EXAMPLE

① **ST32** ② **FMA** - ③ **25.4**

① Shank Size øD1
 ② Name
 ③ øD2

BT series

HSK series

ST series

Versatile Tool

Cutting Tool

Accessories