

オイルホールタッパー

BT[Ⓝ]-OH-TPC[Ⓝ] D₁-L

OIL-HOLE TAP HOLDER

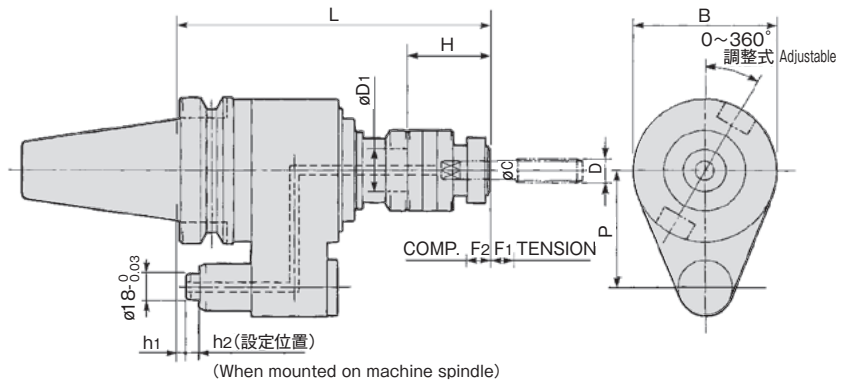

使用条件 CUTTING CONDITIONS

最高切削油圧
MAX.COOLANT PRESSURE 2.0MPa

MODEL	CODE	øD ₁	L	H	B	P	F ₁	F ₂	D	TAP COLLET CODE	
BT40	-OH-TPC20-207	11288	20	207	45	92	65	15	15	M 4~M14	OH-TCC20-Ⓝ
	-TPC29-217	11289	29	217	55					M12~M27	OH-TCC29-Ⓝ
BT50	-OH-TPC20-200	13592	20	200	45	98	80	15	15	M 4~M14	OH-TCC20-Ⓝ
	-TPC29-210	13594	29	210	55					M12~M27	OH-TCC29-Ⓝ
	-TPC40-260	13596	40	260	75	120	85	20	20	M18~M39	OH-TCC40-Ⓝ

注：h1、h2は各メーカー及び機種により異なりますので、御注文頂きます際には、メーカー及び機種を御連絡願います。

NOTE: When ordering, please inform h1 and h2 dimensions, which differ depending on machine maker and model.

ご注文例 ORDERING EXAMPLE

①	BT40	-	②	OH-TPC	③	20	-	④	207
①	シャンクサイズ			Shank Size					
②	呼称			Name					
③	øD ₁			øD ₁					
④	GL長さ L			G.L. Length					



アクセサリ ACCESSORIES

P.60 タップコレット TAP COLLET

BT series

HSK series

ST series

Versatile Tool

Cutting Tool

Accessories

Data