

使用条件 CUTTING CONDITIONS		
	標準 (STD)	オーダ (H)
最高回転数 MAX.RPM	1500min <sup>-1</sup>	3000min <sup>-1</sup>
最高切削油圧 MAX.COOLANT PRESSURE	0.5MPa	2.0MPa

MODEL	CODE	φD	L	φC	H1	H2	H3	G	B	P	
BT40	-OH-SL16-150	11426	16	150	38	25	-	45	M12×1.5	80	65
	-SL20-150	11428	20								
	-SL25-150	11430	25								
	-SL32-165	11432	32								
BT50	-OH-SL16-165	13842	16	165	40	25	-	45	M12×1.5	98	80
	-SL20-165	13844	20								
	-SL25-165	13846	25								
	-SL32-165	13848	32								
	-SL40-165	13850	40								

注：h1、h2は各メーカー及び機種に依り異なりますので、御注文頂きます際には、メーカー及び機種を御連絡願います。

NOTE: 1. When ordering, please inform h1 and h2 dimensions, which differ depending on machine maker and model.

ご注文例 ORDERING EXAMPLE

① BT40 - ② OH-SL ③ 16 - ④ 150

① シャンクサイズ	Shank Size
② 呼称	Name
③ 刃具シャンク径 φD	Cutter's Shank Dia.
④ GL長さ L	G.L. Length

## ストレートスリーブ

### STRAIGHT SLEEVE

### OH-SL(D<sub>1</sub>)-D<sub>2</sub>

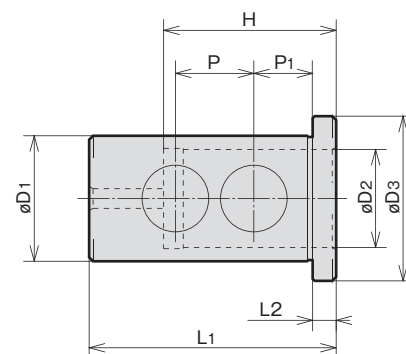

CODE	φD1	φD2	φD3	L1	L2	P	P1	H	N/W (kg)
OH-SL20-16 (-)	20	16	30	48	6	-	25	44	0.07
OH-SL25-16 (-)	25	16	35	58	6	20	15	44	0.19
-20 (-)		20							0.15
OH-SL32-16 (-)	32	16	42	63	6	20	15	44	0.35
-20 (-)		20						0.32	
-25 (-)		25						0.22	
-16 (-)		16						0.57	
OH-SL40-16 (-)	40	16	50	63	6	20	15	40	0.54
-20 (-)		20						0.54	
-25 (-)		25						0.45	
-32 (-)		32						0.30	

注：1. コード (-) 表記製品は在庫が無くなり次第、廃盤品となります。

NOTE: 1. CODE (-) The listed products will be discontinued as soon as it is out of stock.

ご注文例 ORDERING EXAMPLE

① OH-SL ② 20 - ③ 16

① 呼称	Name
② φD1	φD1
③ φD2	φD2