

COLLET CHUCK (SLIM TYPE)

By a super slim body,
it minimizes the interference of work & jig.



POINT

1

Super slim nut and body diameter.

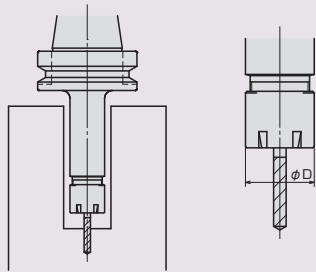

CODE	øD	CHUCK
ER11MN	16	SSC07
ER16MN	22	SSC10
ER20MN	28	SSC13
ER25MN	35	SYFN16S

POINT

2

Standard 16° (DIN6499/ISO15488) taper collet,
the most popular in world.

①Smallest diameter is 0.5mm

CHUCK	COLLET I.D. (mm)	GRIPPING RANGE (mm)
SSC07	ø1~ø7	0.5
SSC10	ø1~ø3	0.5
	ø4~ø10	1.0
SSC13	ø1~ø3	0.5
	ø4~ø13	1.0
SYFN16S	ø1.5~ø3	0.5
	ø4~ø16	1.0

②High accuracy collets are used.

③The Collet is made of quality alloy steel which minimizes strain and wear.

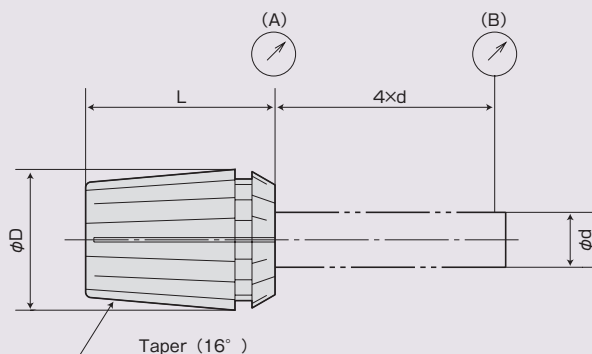

GRADE	RUNOUT	
	NOSE	4D POINT
AA	1μm	3μm

DIMENSIONS

BT ▶ P.59 | HSK ▶ P.127

POINT

3

Long adapter for synchronized tap holder (COLLET CHUCK SLIM TYPE)

3

It is possible to use it as a long adapter by chucking it with Synchro Tap Holder SYFN20 type.

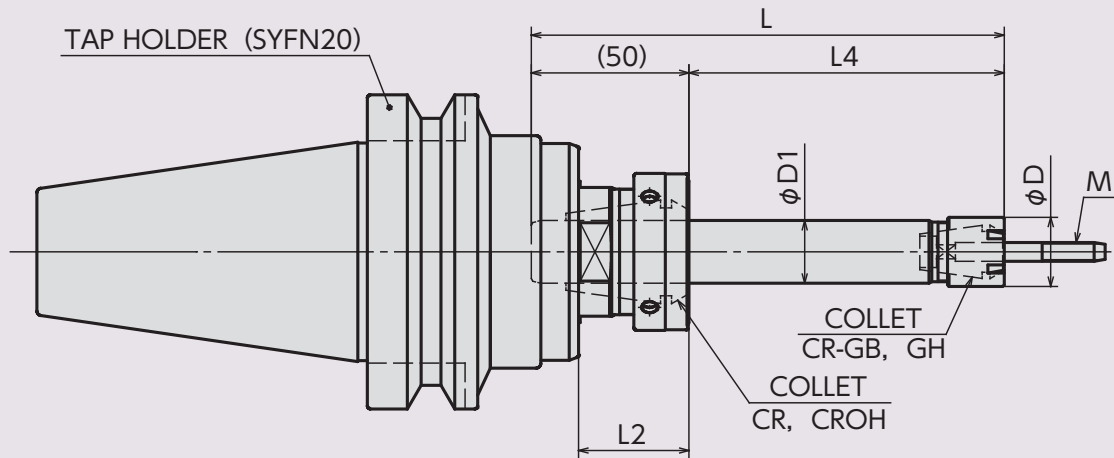

ADAPTER MODEL	ϕD	$\phi D1$	L4	M
ST16-SSC07-L	16	16	50, 100 150	M6
ST20-SSC10-L	22	20	50, 100 150, 200	M10
ST20-SSC13-L	28	20	100 150	M12

TAP HOLDER MODEL	ϕD	$\phi D1$	L2	M
SYFN16S-L2	35	—	35,65 95,125,155	M16

When it is necessary to dig a deeper hole for tap processing of M14-M16, it is possible to use by tap holder SYFN16S type without long adapter.

POINT

4

It is available as a long adapter for small diameter drill processing

▽